

ESC 100-12 12V100.0Ah

SPECIFICATION

● NOMINAL VOLTAGE	: 12 V
● NOMINAL CAPACITY(20 hr)	: 100.0Ah
● DIMENSIONS	
TOTAL HEIGHT	: 221 mm (8.70 inches)
CONTAINER HEIGHT	: 214 mm (8.43 inches)
LENGTH	: 329 mm (12.95 inches)
WIDTH	: 172 mm (6.77 inches)
● WEIGHT	: APPROX 32.80Kg
● CONTAINER MATERIAL	: UL94HB ABS : UL94V-0 ABS
● INTERNAL RESISTANCE(25°C , 77 °F)	: ~5.0 mΩ
● DISCHARGE CAPACITY UNDER DIFFERENT TEMPERATURES	
40°C	: ~102%
25°C	: ~100%
0 °C	: ~85%



ESC100-12 is a long life, high performance battery designed for standby and cyclical applications. ESC batteries are capable of delivering up to 500 cycles at 50% depth of discharge.

CHARACTERISTICS

● CAPACITY 25°C / 77 °F	
20 hr @ 5 A	: 100.0 Ah
5 hr @ 17 A	: 85.0 Ah
1 hr @ 61 A	: 61.0 Ah
1 C @ 100 A	: 50.0 Ah
● CHARGING VOLTAGE (25°C , 77 °F)	
STANDBY USE	: 13.62V/bloc
FREQUENT DISCHARGE USE	: 14.1-14.4 V/bloc
● MAX CHARGING CURRENT	: 25 A
● SELF-DISCHARGE RESIDUAL CAPACITY(25°C , 77 °F)	
AFTER 3 MONTHS	: ~90%
AFTER 6 MONTHS	: ~82%
AFTER 12 MONTHS	: ~70%

DISCHARGE CHARACTERISTICS 25°C (77°F)

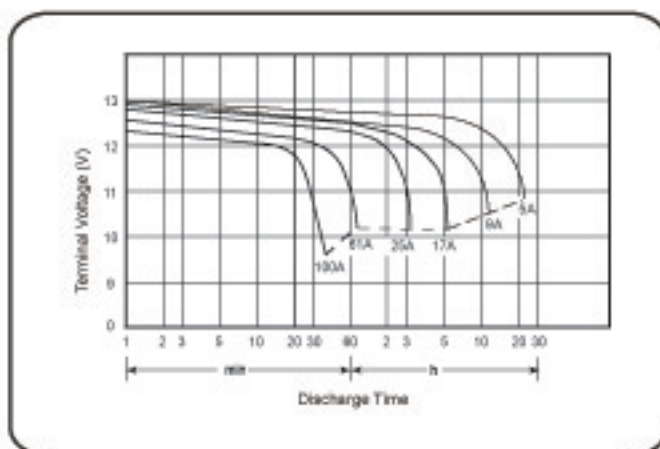

DIMENSIONS

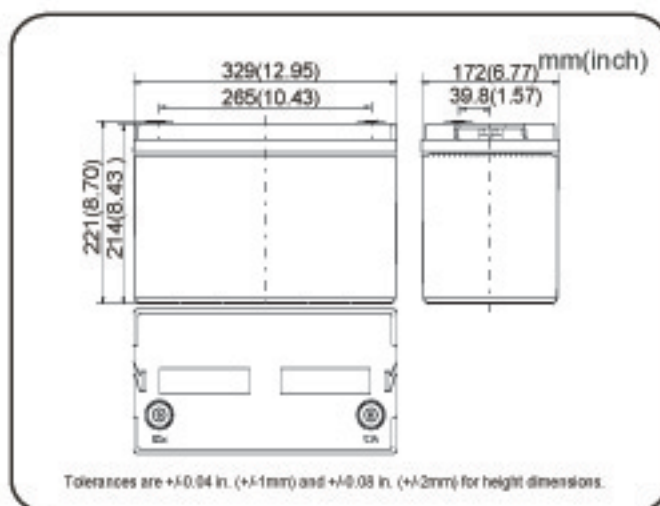

TERMINAL

