

SPECIFICATION

● NOMINAL VOLTAGE	: 12 V
● NOMINAL CAPACITY(20 hr)	: 18.0 Ah
● DIMENSIONS	
TOTAL HEIGHT	: 167 mm (6.57 inches)
CONTAINER HEIGHT	: 167 mm (6.57 inches)
LENGTH	: 181 mm (7.13 inches)
WIDTH	: 76 mm (2.99 inches)
● WEIGHT	: APPROX 5.8 Kg
● CONTAINER MATERIAL	: UL94HB ABS
	: UL94V-0 ABS
● INTERNAL RESISTANCE(25°C , 77 °F)	: ~14mΩ
● DISCHARGE CAPACITY UNDER DIFFERENT TEMPERATURES	
40°C	: ~102%
25°C	: ~100%
0 °C	: ~85%



ES18-12 is a general purpose battery with 3~5 years in standby service or more than 400 cycles at 50% depth of discharge in cycle service.

CHARACTERISTICS

● CAPACITY 25°C / 77 °F	
20 hr @ 0.9 A	: 18.0 Ah
5 hr @ 3.06 A	: 15.30 Ah
1 hr @ 11.34 A	: 11.34 Ah
1 C @ 18 A	: 9.0 Ah
● CHARGING VOLTAGE (25°C , 77 °F)	
STANDBY USE	: 13.68V/bloc
FREQUENT DISCHARGE USE	: 14.1-14.4 V/bloc
● MAX CHARGING CURRENT	: 4.5 A
● SELF-DISCHARGE RESIDUAL CAPACITY(25°C , 77 °F)	
AFTER 3 MONTHS	: ~90%
AFTER 6 MONTHS	: ~82%
AFTER 12 MONTHS	: ~70%

DISCHARGE CHARACTERISTICS 25°C (77°F)

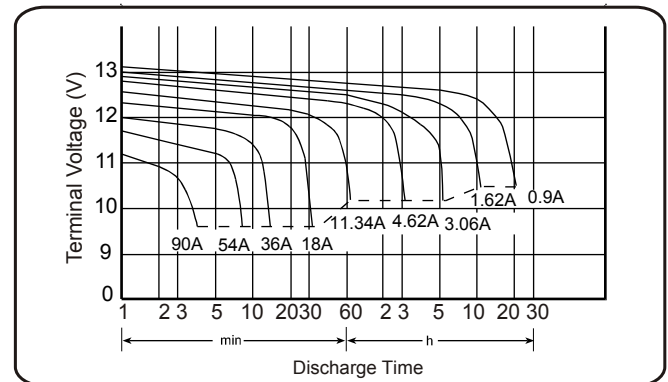

DIMENSIONS

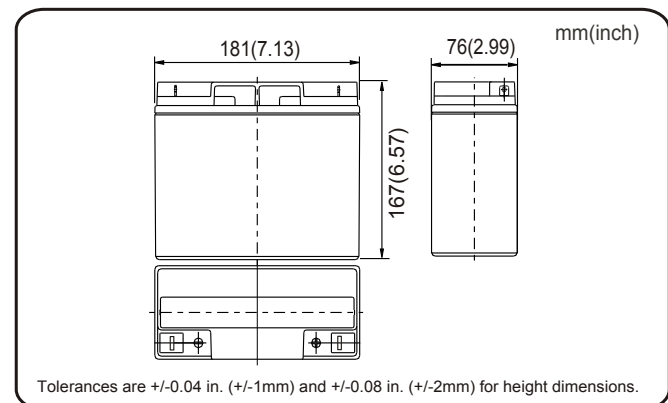

TERMINAL

